

VF 1904

Vertical Form Fill Seal



NEW High-Speed Vertical Form Fill Seal System for Various Products and Pouch Sizes

- Up to 200 Cycles Per Minute
- No maximum length
- Up to 12 lanes wide
- Continuous motion
- Quick changeovers



VF 1904

Vertical Form Fill Seal

Standard Features:

- Up to 200 Cycles Per Minute
- Highest Speed in Industry on Multi-Lane Machine
- Equivalent of Max. 2400 PPM or 1.152 Mil PP Shift
- Filling Weights Start at .05 fl. oz. (1.5 grams)
- Package Length Starts at 2.5 Inches (63.5 mm)
- No Maximum Length
- Film / Web Width up to 19.5 Inches (495.3 mm)
- Film Web Never Stops While in Operation
- Up to 12 Lanes Wide (12 pouches / cycle)
- Volumetric Piston Fillers for Fill Accuracy
- 10 Gallon Product Tank (optional)

Applications:

Water based or any other viscous product.

Machinery Specifications:

Carton Specifications:

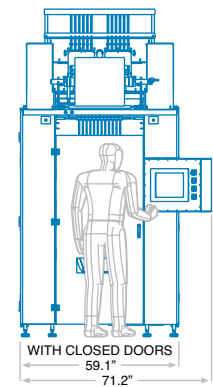
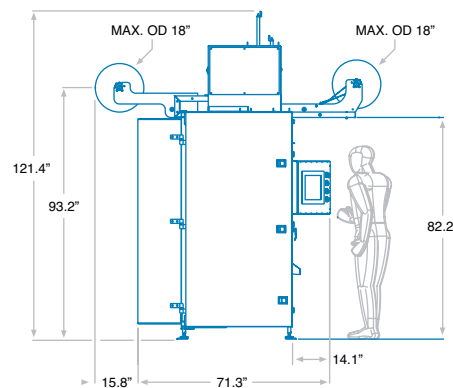
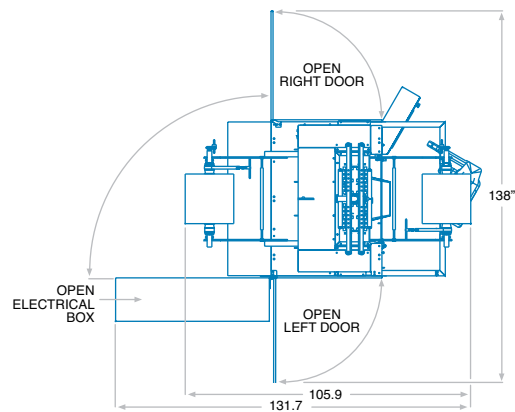
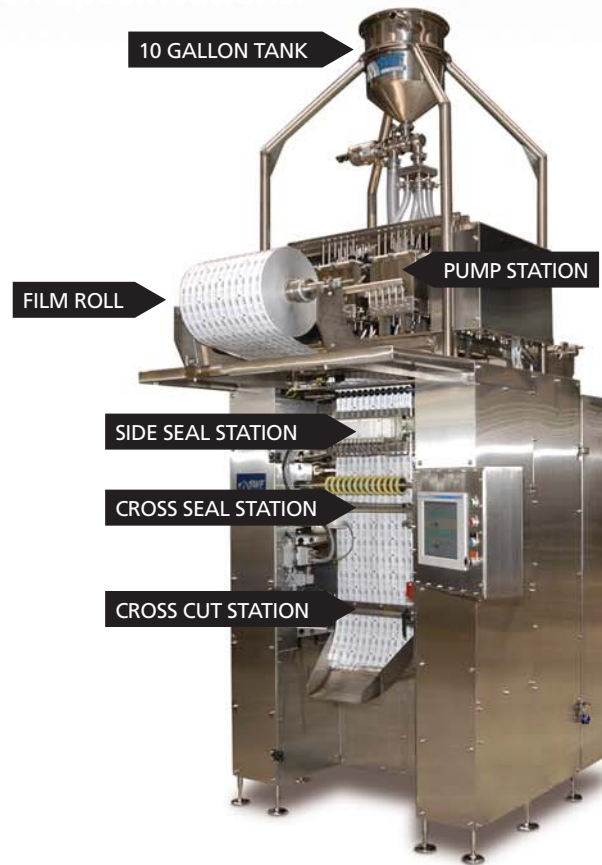

www.swfcompanies.com | 800.344.8951 | info@swfcompanies.com

